



Defining Quality. Building Comfort.

# Single Zone VAV

Discover how to save money, reduce energy consumption and lower sound levels.

## What is single zone VAV?

Single zone VAV, or single zone variable air volume, is an HVAC application in which the HVAC unit varies the airflow at constant temperature to provide space temperature control. A constant volume HVAC unit supplies constant airflow with variable temperature to provide temperature control. In the cooling mode, to meet ventilation requirements, the fan operates continuously and the compressor cycles on and off to meet the space cooling load. The fan and compressor operate at full capacity until the temperature drops to a set lower limit below the setpoint; then the compressor turns off. The compressor turns on again at full capacity once the space temperature increases to a set upper limit above the setpoint. The on/off nature of the constant volume unit causes the temperature to constantly fluctuate above and below the room setpoint temperature.

In a single zone VAV unit, a variable speed fan controls the amount of airflow provided to the space by modulating the fan motor speed based on the difference between the actual space temperature and the temperature setpoint. The modulating compressor uses the temperature of the supply air leaving the unit to determine how much refrigerant flow is needed to maintain the supply air temperature setpoint.

The fan and compressor continue to modulate to precisely meet the desired space temperature. For part load conditions, the single zone VAV unit will operate at a lower fan speed for a greater amount of time, saving valuable energy and providing the space with more constant temperature and humidity control. HVAC systems generally operate at part load conditions for a majority of the year, and during these part load conditions the operation of a single zone VAV system provides many benefits. First, a single zone VAV system will operate at a lower fan speed than a constant volume system, resulting in less fan energy consumption. Second, with the modulation capabilities of both the fan and compressor a single zone VAV system can provide precise temperature control and additional passive

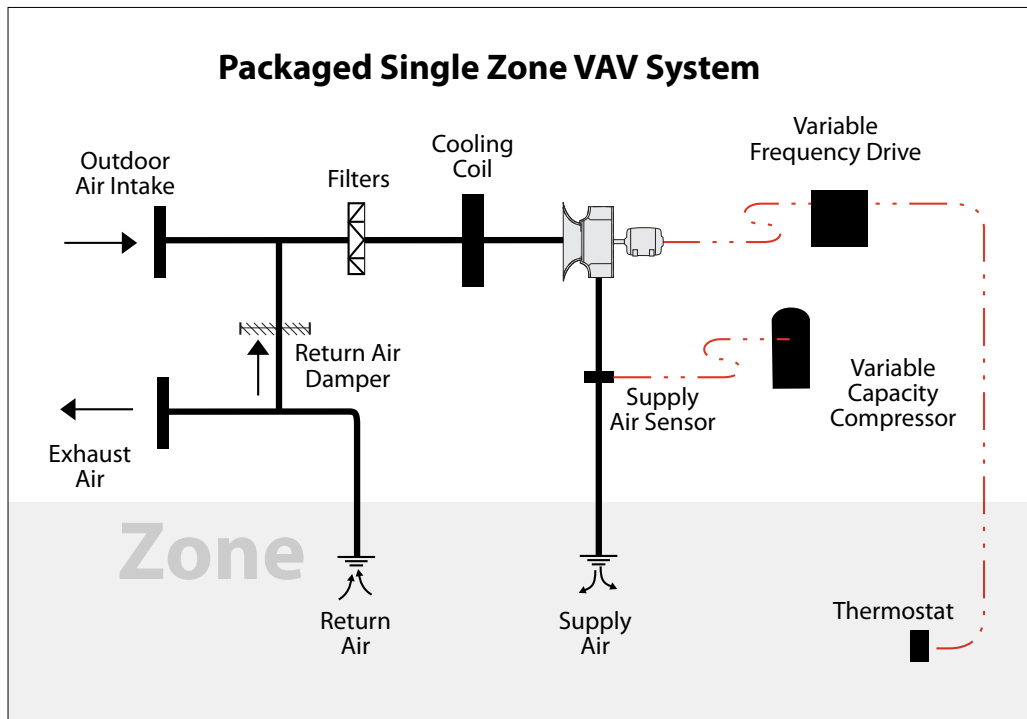

dehumidification. Third, the modulation capabilities of the compressor reduce the amount of compressor on/off cycling, reducing wear on the compressor and providing greater energy savings than hot gas bypass systems. Fourth, lower fan speeds reduce the amount of sound produced by the supply fan. Finally, with the entire modulating control for part load operation provided within the HVAC unit, a single zone VAV system is simple to install, set up and maintain.

Single zone VAV is used for areas where the occupancy or space cooling needs vary throughout the day such as classrooms, conference rooms, assembly halls, auditoriums, libraries, hospitals, supermarkets, convenience stores, restaurants, churches, health clubs, museums, office buildings, manufacturing facilities, lodgings, retail buildings, warehouses, etc.

AAON is leading the industry in single zone VAV technology with both variable speed fans and variable capacity compressors which have a wide range of modulation capabilities that adapt to full and part load conditions. Benefits of single zone VAV include a more comfortable indoor environment with precise space temperature control and improved humidity control, significant energy savings, less wear on the compressor, a reduction in fan noise and simple installation and maintenance.

## Energy savings

One of the main advantages of varying the fan speed is energy savings. It takes less energy to run a fan at lower rotational speeds. The fan law that relates fan input horsepower to fan rotational speed is:

$$HP_2 = HP_1 \cdot \left(\frac{D_2}{D_1}\right)^5 \cdot \left(\frac{rpm_2}{rpm_1}\right)^3 \cdot \frac{\rho_2}{\rho_1}$$

where  $D$  is the fan diameter,  $\rho$  is the air density,  $HP$  is the input horsepower, and  $rpm$  is the fan rotational speed. This law says that, assuming the diameter and air density do not change, the fan power input is proportional to the cube of the fan rotational speed:

$$HP_2 = HP_1 \cdot \left(\frac{D_2}{D_1}\right)^5 \cdot \left(\frac{rpm_2}{rpm_1}\right)^3 \cdot \frac{\rho_2}{\rho_1} \Rightarrow HP_2 = HP_1 \cdot \left(\frac{rpm_2}{rpm_1}\right)^3$$

For the same fan diameter and air conditions, cutting the fan rotational speed in half cuts the required input horsepower by eight! This law is illustrated graphically in Figure 1, where brake horsepower is the amount of input power needed for the given fan rotational speed.

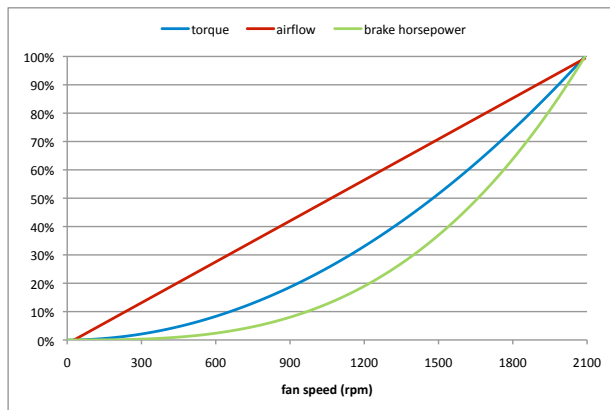

Figure 1: Brake Horsepower, Torque, and Airflow as a Percentage of Full Capacity versus Fan Speed

A single zone VAV unit also saves energy due to reduced cycling losses in the compressor. When power is first applied to a motor, the current is significantly higher for a short period of time until the motor reaches its normal operating current. This initial inrush current can be as much as twenty times the normal operating current. Fans and compressors consume significantly more power when the motor is first turned on than at steady state operation. This initial inrush does no useful work but is required to take the motor from a stopped state to a state of motion. In addition to the inrush current, the compressor also loses energy during on/off cycling due to the work the compressor does to initiate the flow of refrigerant through the compressor. As the compressor is turned on, a pressure difference is created from the suction to the discharge of the compressor to start the flow of refrigerant. It takes more work to initially create this pressure difference and start the refrigerant flow than it does to maintain the refrigerant flow during reduced load. For constant volume systems in which the compressor is cycled on and off more often, more energy is consumed during frequent startups.

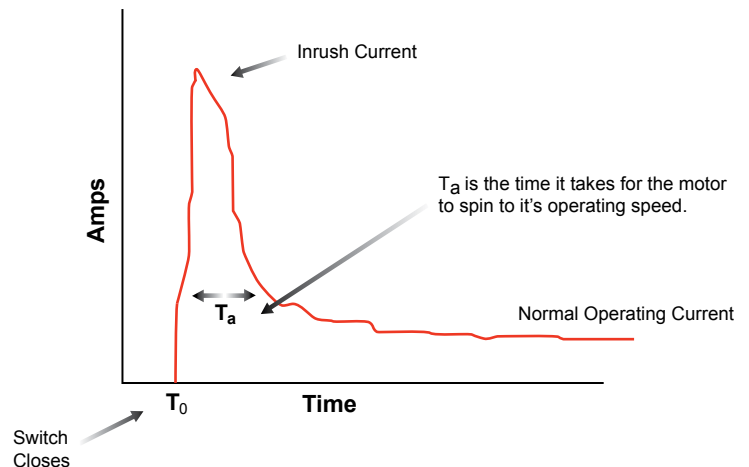

Figure 2: Example of Motor Inrush Current

How much energy does a single zone VAV unit save? The monthly fan and direct expansion cooling energy usage for a constant volume unit and a single zone VAV unit are shown in Figures 4 through 10 for various ASHRAE climate zones. Both units are 25 tons in capacity and are evaluated for a single zone of 10,000 square feet that is occupied Monday thru

Friday from 7 am to 7 pm and Saturdays from 8 am to noon with 100 people doing light work. The occupied heating and cooling setpoints are 68°F and 74°F, respectively. The unoccupied heating and cooling setpoints are 55°F and 90°F, respectively. The single zone VAV unit is controlled with a fixed 54 degree coil temperature setpoint. The constant volume unit is controlled with zone control reset with a range of 54 to 58 degrees.

The constant volume unit contains a standard, single speed fan and two standard fixed capacity scroll compressors. The single zone VAV unit contains a variable speed fan and two variable capacity scroll compressors.

## Sample Savings by ASHRAE Zone

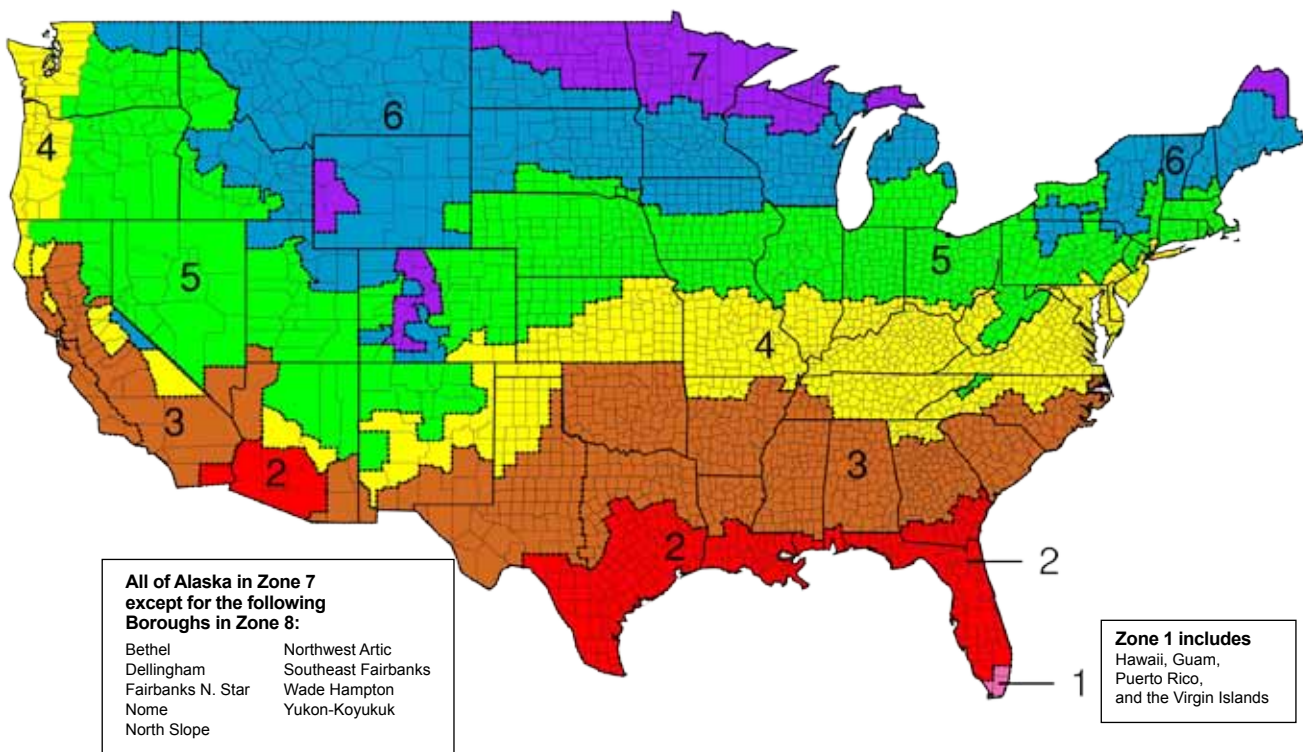

Figure 3: ASHRAE Zone map

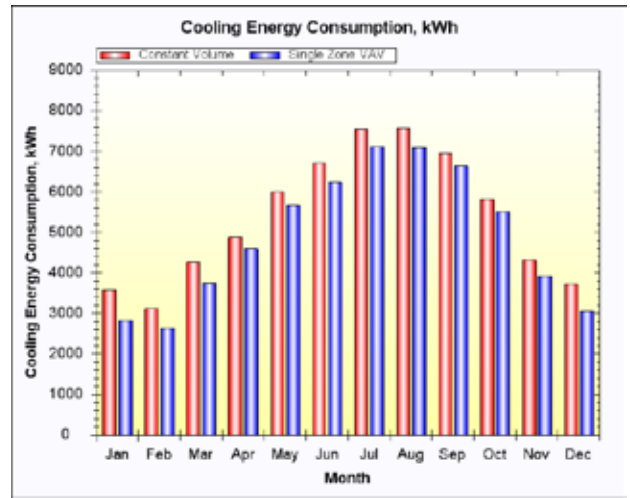
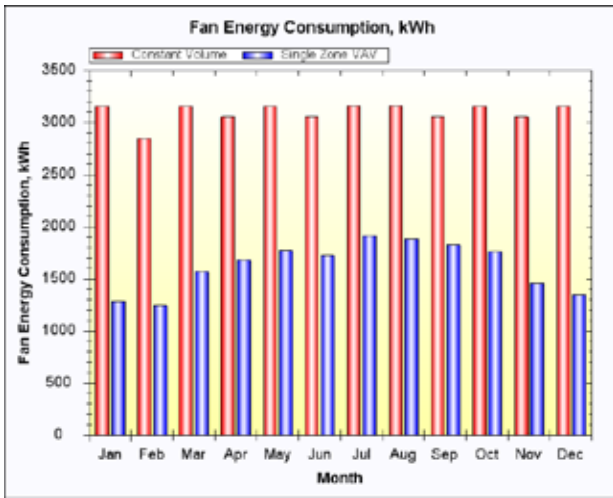

Figure 4: Sample fan and DX cooling energy usage for ASHRAE Zone 1

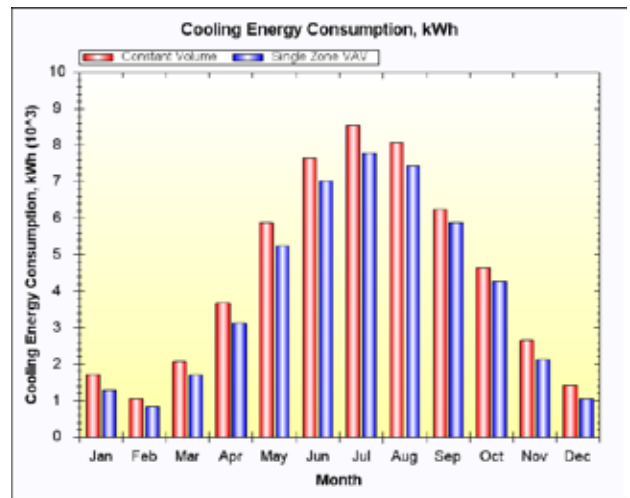
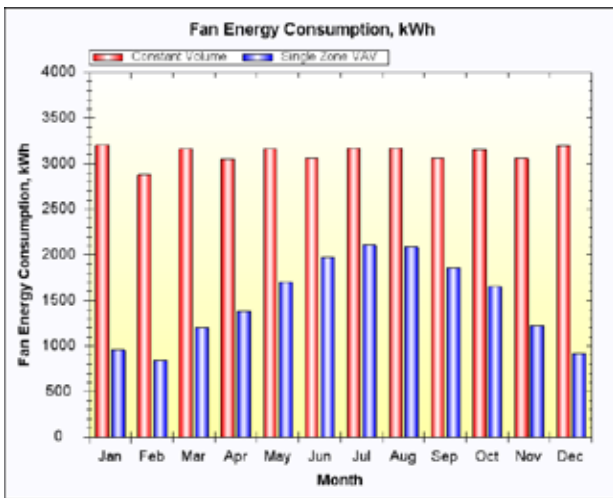

Figure 5: Sample fan and DX cooling energy usage for ASHRAE Zone 2

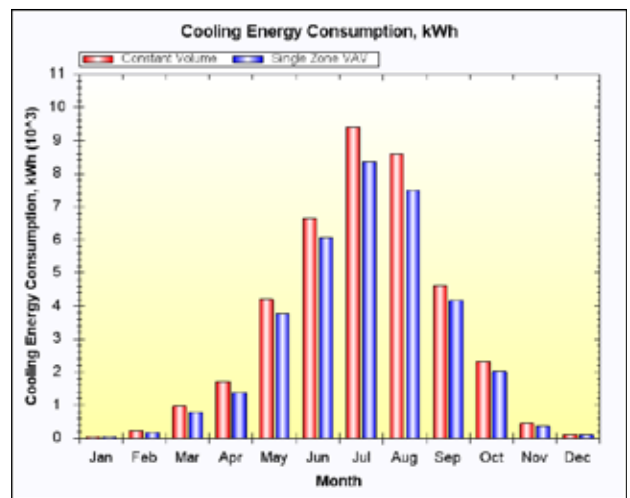
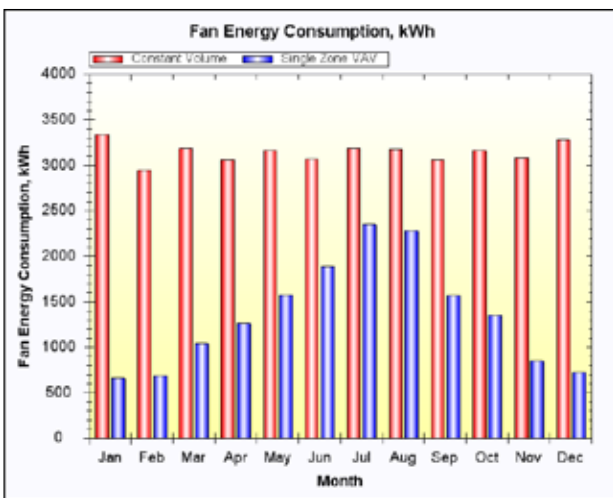

Figure 6: Sample fan and DX cooling energy usage for ASHRAE Zone 3

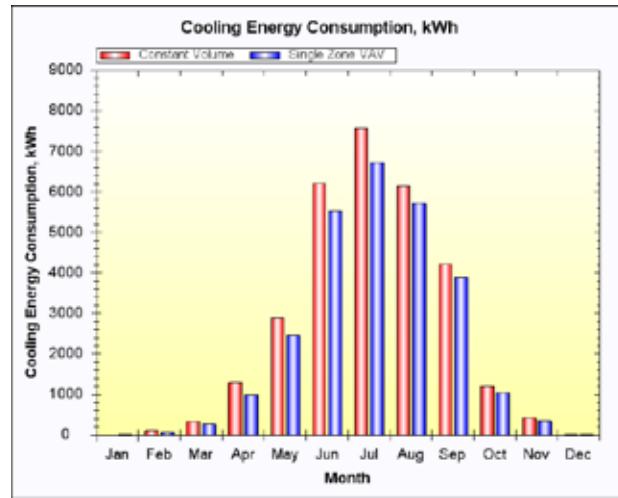
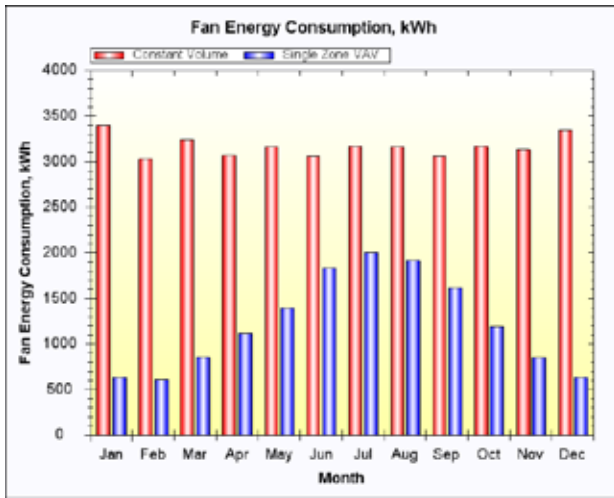

Figure 7: Sample fan and DX cooling energy usage for ASHRAE Zone 4

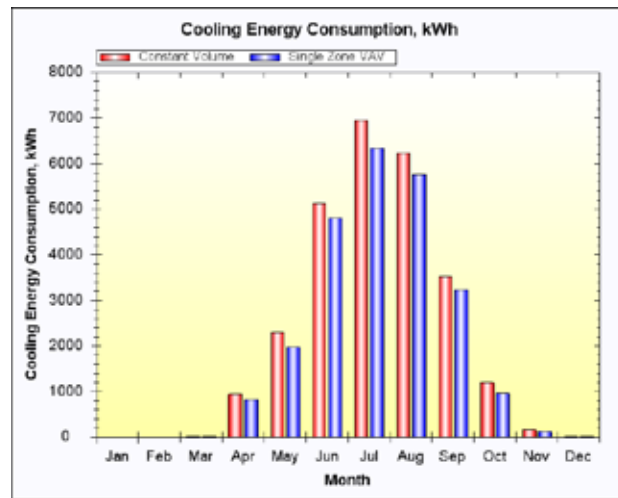
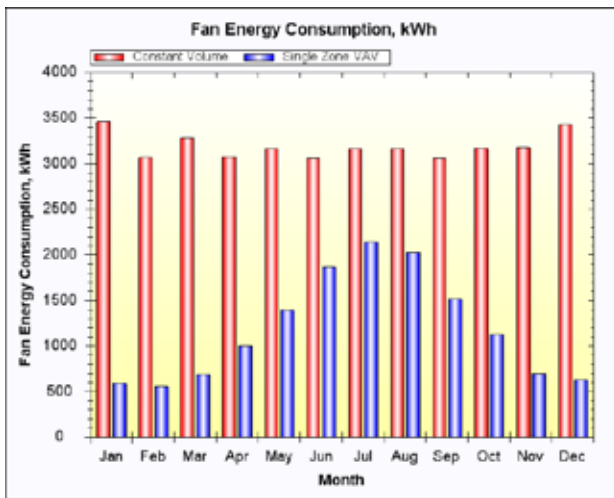

Figure 8: Sample fan and DX cooling energy usage for ASHRAE Zone 5

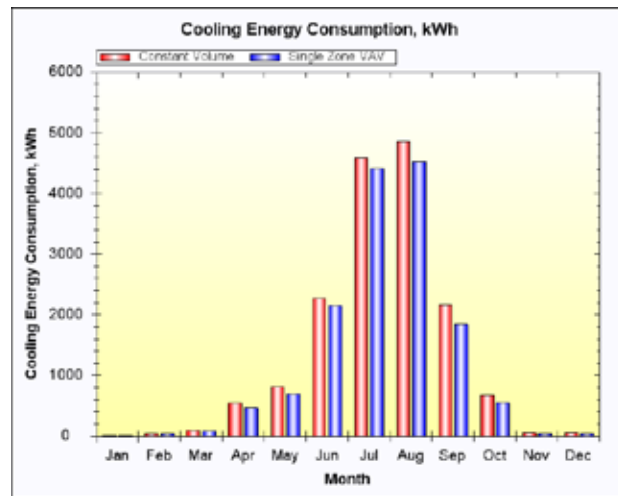
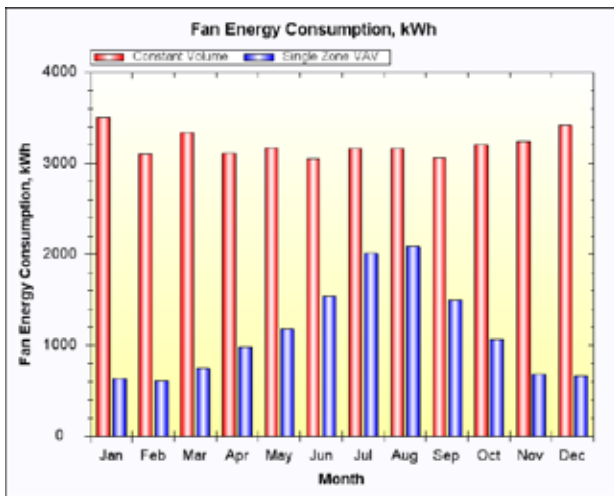

Figure 9: Sample fan and DX cooling energy usage for ASHRAE Zone 6

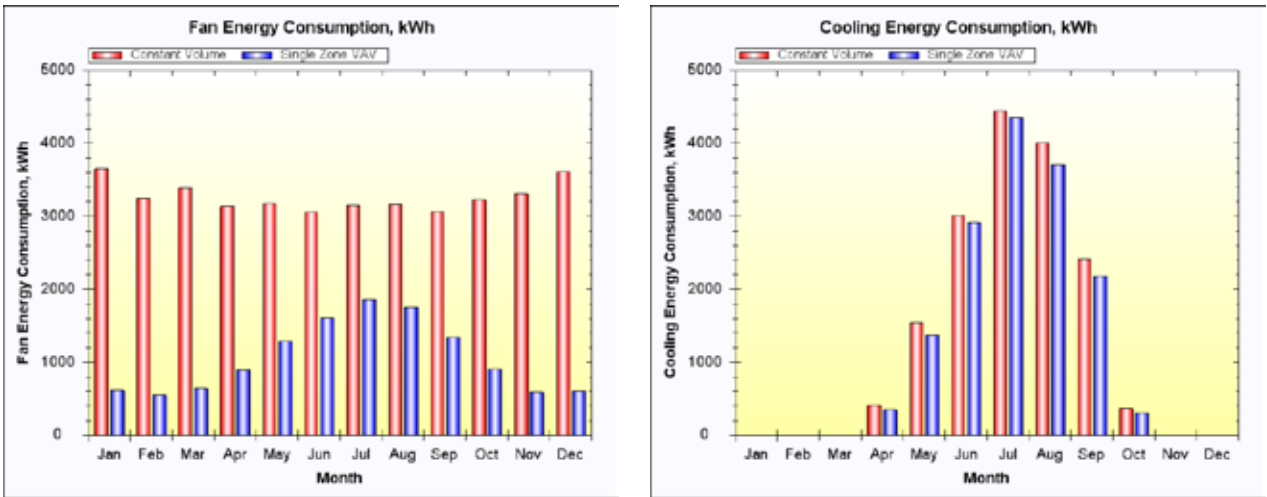

Figure 10: Sample fan and DX cooling energy usage for ASHRAE Zone 7

The energy usage of the constant volume unit is significantly more than the energy usage of a single zone VAV unit. The energy costs are greater for the constant volume system due to both increased usage charges and increased demand charges. Utility companies bill commercial energy on the basis of both usage and demand. The usage charge is simply the total energy used multiplied by the usage rate. The demand charge takes the greatest peak load during a given time period and multiplies the peak load by the demand usage rate. The single zone VAV unit only runs at full energy load when the space conditions require it. The single zone VAV unit saves a greater amount in energy costs than a comparable constant volume system because of the ability to adapt to the space needs.

## Noise Reduction

One of the main sources of sound in an HVAC unit is the fan operation. The faster the fan rotates, the more sound the system produces. The relationship between fan speed and A-weighted sound power level for an example AAON unit with a backward curved plenum fan is shown in Figure 11.

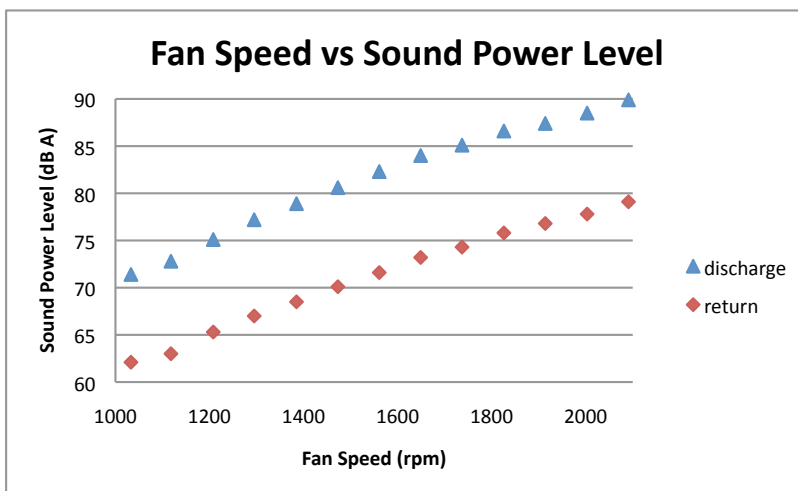

Figure 11: A-weighted Sound Power Level versus Fan Speed

Because a single zone VAV unit varies the fan speed as needed by space conditions, the fan will be running at lower speeds than a constant volume unit unless the space conditions require the fan to operate at full capacity. The difference in sound power level as the fan speed increases from 1,000 rpm to 2,100 rpm, a little over twice the fan speed, increases the discharge sound power level by 18.5 dBA and the return sound power level by 17 dBA. The sound increase caused by the increase in fan speed is perceived by the human ear as an increase in loudness of about four times the sound of the original, lower speed fan. This means that by simply reducing the fan speed by half, the unit is almost four times quieter!

# Passive Dehumidification

As warm air passes over a cold cooling coil, the warm air transfers heat to the coil resulting in colder air as shown in Figure 12.

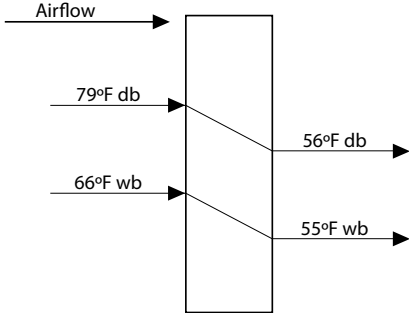

Figure 12: Heat transfer through cooling coil

The amount of energy that is removed from the air as it passes over the cooling coil is given by the following equation:

$$Q = \dot{m} \cdot \Delta h$$

where  $Q$  is the capacity of the coil,  $\dot{m}$  is the airflow across the coil, and  $\Delta h$  is the change in enthalpy from before the cooling coil to after the cooling coil. The change in the enthalpy of the air as it passes over the cooling coil is equal to the total change in internal energy (or the total amount of heat gained or lost). As sensible cooling occurs and without moisture removal from the air, heat is removed from the air resulting in a reduction in the supply air temperature. As latent cooling occurs and moisture in the air is removed, condensation appears on the cooling coil(s) and energy is removed from the air without a reduction in temperature. The total energy lost by the air as it cools is equal to the sensible heat removal plus the latent heat removal.

$$Q = \overbrace{\dot{m} \cdot c_p \cdot \Delta T}^{\text{sensible cooling}} + \overbrace{\dot{m} \cdot h_{fg} \cdot \Delta W}^{\text{latent cooling}}$$

where  $Q$  is the capacity of the coil,  $\dot{m}$  is the airflow across the coil,  $c_p$  is the specific heat capacity of the air,  $\Delta T$  is the temperature change of the air as it passes over the coil,  $h_{fg}$  is the enthalpy of vaporization, and  $\Delta W$  is the change in the humidity ratio as the air passes over the coil.

If the airflow is reduced, and in order to maintain the same amount of cooling,  $\Delta h$  must increase. For two different units, one constant volume and one single zone VAV, with the same return and outside air conditions, the reduction in airflow of the single zone VAV unit compared to the constant volume unit means that the air is exposed to the cooling coil for a longer amount of time, resulting in the single zone VAV unit having a lower supply air temperature than a constant volume system under the same operating conditions. Cooler air holds less moisture than warmer air. When the cooling coils are colder than the wet bulb temperature of the entering air, dehumidification occurs as can be seen in the psychrometric chart in Figure 13.

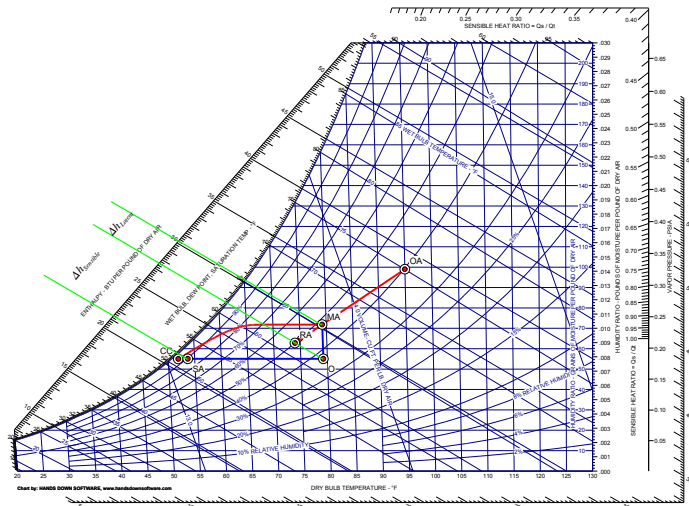

Figure 13: Cooling Coil Psychrometric Example

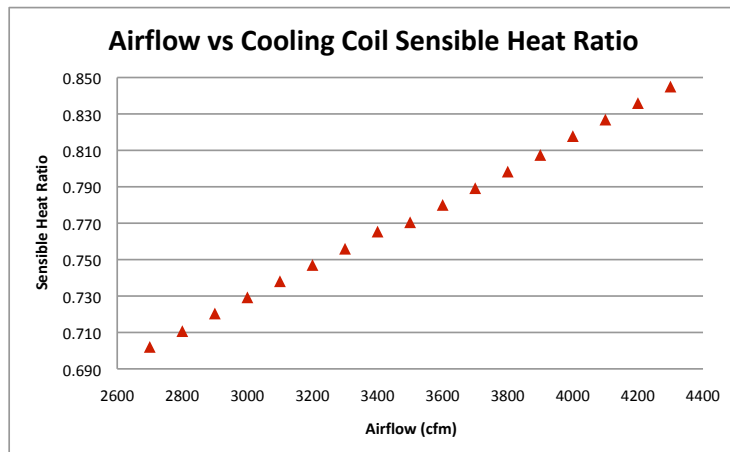

Figure 14: System Sensible Heat Ratio versus Airflow

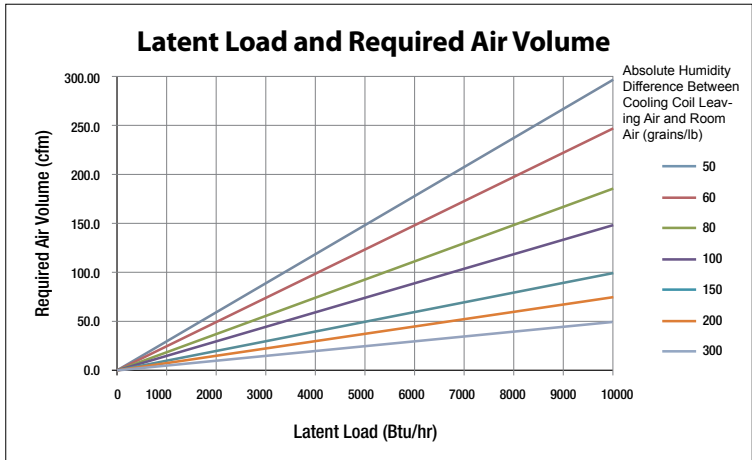

Figure 15: Required Air Volume versus Latent Load

As the air is passed over the cooling coils in a single zone VAV unit, more of the moisture condenses on the coils, dehumidifying the air, than in a constant volume unit. This means that although a constant volume and a single zone VAV unit maintain the same room temperature for a given space, the single zone VAV unit provides more space dehumidification, providing more comfortable space conditions. The relationship between airflow and system sensible heat ratio is illustrated in Figure 14 and the required air volume for given latent loads and desired absolute humidity difference is shown in Figure 15.

Traditional constant volume HVAC units are often only able to provide adequate humidity control under very limited space loads and outdoor air conditions. For example, consider a classroom with 30 students doing light, seated work. Allowing 15 cfm per person of outside air, 450 cfm of outside air is needed for this classroom. The latent load per person can be approximated at 155 Btu/hr, providing a metabolic latent load of 4,650 Btu/hr for the fully occupied classroom. Assuming outdoor air conditions of 95°F db/ 75°F wb and a desired room temperature of 74°F with 50% relative humidity with 450 cfm of outside air, the outside air room ventilation provides an additional latent load of 11,500 Btu/hr for a total latent load of 16,200 Btu/hr at full occupancy. At full load the room has a sensible load of 64,700 Btu/hr, yielding a sensible heat ratio of 0.8. These given conditions require about 3,000 cfm of airflow to the room to maintain 50% relative humidity. What happens to this same room under reduced sensible conditions?

Room Sensible Heat Ratio	Constant Volume			Single Zone VAV		
	Relative Humidity	Latent Cooling (Btu/hr)	Airflow (cfm)	Relative Humidity	Latent Cooling (Btu/hr)	Airflow (cfm)
0.80	51.0%	27,000	3,000	51.0%	27,000	3,000
0.75	59.7%	23,541	3,000	50.0%	27,347	2,000
0.70	66.3%	20,887	3,000	51.9%	26,604	1,500
0.65	71.5%	18,817	3,000	52.0%	26,565	1,000
0.60	75.7%	17,162	3,000	56.4%	24,852	800
0.55	79.1%	15,812	3,000	61.2%	22,923	600

Figure 16: Relative humidity and Airflow for Varying System Sensible Loads

Let's assume that the room sensible load decreases with the same room metabolic latent load, as if the computers or lights are turned off, the blinds are closed, or it's a cloudy day outside. Figures 16 and 17 show the relative humidity and airflow for various sensible heat ratios for the same classroom with the full latent load but reduced sensible load. The figure shows what happens when the classroom is fully occupied but the lights are turned off or the blinds are down, thus reducing the sensible load while the latent load stays the same.

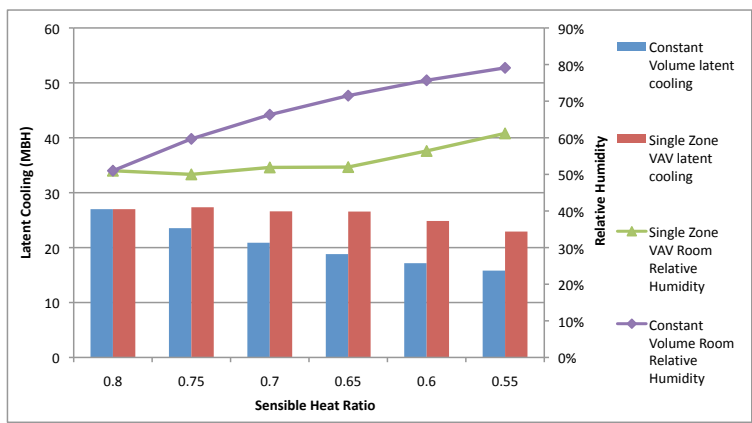

Figure 17: Latent Cooling and Relative Humidity (Decreased Sensible Load) versus Sensible Heat Ratio

Room Sensible Heat Ratio	Constant Volume			Single Zone VAV		
	Relative Humidity	Latent Cooling (Btu/hr)	Airflow (cfm)	Relative Humidity	Latent Cooling (Btu/hr)	Airflow (cfm)
0.80	51.0%	27,000	3,000	51.0%	27,000	3,000
0.75	52.9%	31,612	3,000	48.5%	33,368	2,500
0.70	55.3%	36,847	3,000	51.3%	38,415	2,500
0.65	58.0%	42,887	3,000	50.9%	45,714	2,000
0.60	61.2%	49,934	3,000	55.2%	52,320	1,900
0.55	64.9%	58,262	3,000	61.1%	59,784	1,900

Figure 18: Relative humidity and Airflow for Varying System Latent Loads

Now let's consider the case when the sensible load stays the same but the latent load increases. This might happen if, for example, the classroom next door joins the class for a lesson or if the student's parents stop by for career day. Figures 18 and 19 show the relative humidity and airflow for various sensible heat ratios for the same classroom sensible load with increasing latent loads.

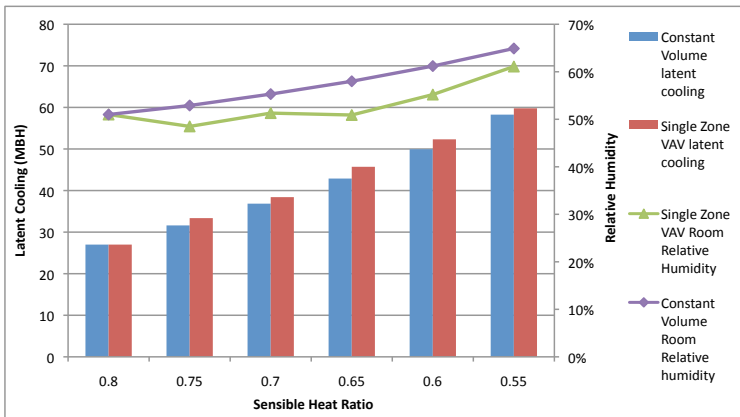

Figure 19: Latent Cooling and Relative Humidity (Increased Latent Load) versus Sensible Heat Ratio

The psychrometric charts for a constant volume system and a single zone VAV system are shown in Figure 20 and 21 for the same classroom described above with a room sensible load of 16,200 Btu/hr and a room sensible heat ratio of 0.6. The cooling coil leaving air temperature for the single zone VAV system is much lower than the cooling coil leaving air temperature of the constant volume system. As a result of this lower cooling coil leaving air temperature, the single zone VAV system is able to provide a greater amount of dehumidification.

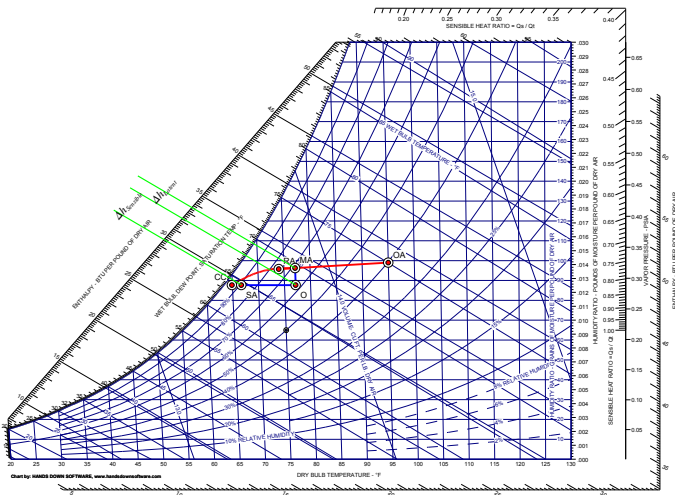

Figure 20: Psychrometric Chart for Constant Volume System

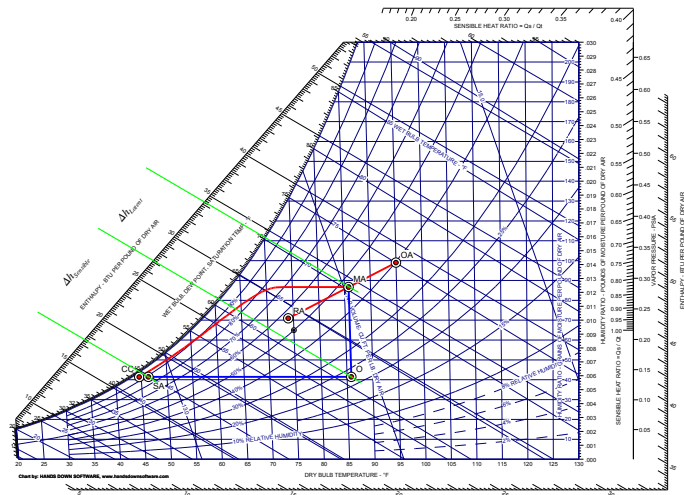

Figure 21: Psychrometric Chart for Single Zone VAV System

ASHRAE Standard 62.1 states that in order to maintain comfortable indoor air conditions, the room relative humidity must be below 0.012 lbw/lba which corresponds to a relative humidity of 65% at 74°F. Single zone VAV units provide greater dehumidification at all part load conditions in which the sensible heat ratio decreases from design specifications. During part-load conditions in which the latent load is at design specifications and the sensible load decreases significantly, the constant volume unit is not able to maintain a relative humidity according to ASHRAE Standard 62.1. For conditions in which humidity control is needed while not much sensible cooling is necessary, the constant volume unit is not able to maintain acceptable room comfort standards. A constant volume system is unable to adequately control the room humidity as the room conditions vary from full load design conditions. A single zone VAV unit does not directly measure and control the room humidity but still provides much more latent cooling at part load conditions than a constant volume system due to passive dehumidification.

In passive dehumidification, the humidity is not directly measured or controlled. In the absence of a reheat source, the cooling coil, and corresponding variable capacity compressor, can control temperature or humidity but one must be primary. If direct humidity control is needed in addition to direct temperature control, a reheat option can be added to a standard single zone VAV unit for use when space humidity conditions are not being met. In dehumidification mode, a single zone VAV unit with a reheat coil will use the cooling coil and compressor to control the space humidity by subcooling the air until the required amount of moisture is removed from the air. The reheat option is used to reheat the air, providing only sensible energy to the supply air. This allows the air to directly meet the space humidity and temperature needs. For more information on reheat options and direct humidity control, refer to the “Modulating Temperature and Humidity Control” brochure by AAON.

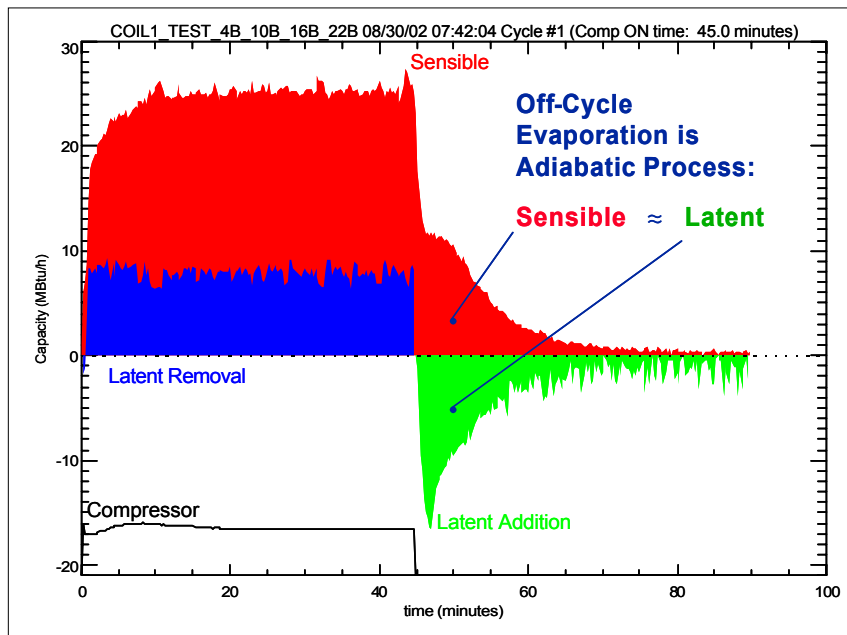

Figure 22: Sensible and Latent Capacity with Continuous Supply Air Fan Operation

## Off-Cycle Condensate Re-evaporation

In the previous section, all latent cooling benefits were calculated at steady-state operation (no on/off cycling). Latent cooling benefits are even greater for a single zone VAV unit if we consider the on/off cycling of the compressor. When air is dehumidified, moisture that is removed from the air condenses on the cooling coil, leaving water droplets on the cooling coil. When the compressor is turned off and the fan remains on, this condensate re-evaporates into the air, undoing the latent cooling benefits. This re-humidified air then enters the room and is cycled back into the HVAC unit and conditioned again through return air. The HVAC unit then has to dehumidify this air again performing dehumidification work twice and consuming large amounts of energy in the condensation-evaporation process. The re-humidification due to on/off cycling is even greater in constant volume units that turn the compressor off while the fan is still running. This allows the unit to maximize the amount of space sensible cooling while the evaporator coils are still cold but the compressor is turned off. However the air that is blowing over the cooling coils simply picks up the moisture and transfers it to the space because the compressor is not operating and dehumidification has decreased and evaporation has begun. The sensible and latent capacity with continuous supply fan operation was examined by Henderson, Shirey, and Raustad and presented at the CIBSE/ASHRAE Conference on September 2003. Their field test data, given in DOE/NETL Project #DE-FC26-01NT41253 is shown in Figure 22.

In Figure 22, the compressor and fan are both running at full capacity for the first 45 minutes of operation then for the next 45 minutes the compressor is turned off while the fan is still running at full capacity. Sensible cooling is represented by the red area, latent heat removal is represented by the blue area, and latent heat addition is represented by the green area. The field test data shows that as the compressor turns off while the fan is still running, latent heat is added to the space while some sensible heat is removed. Figure 22 shows that as the compressor turns on, it takes a certain amount of time for the compressor to reach its full sensible and latent capacity. This means that energy is wasted each time the compressor is turned on while the temperature of the cooling coils reaches its steady state. In addition to this, every time the compressor is turned off while the supply fan continues to run, moisture is added back to the space, wasting a large amount of the energy that was consumed to remove the moisture. Estimating the amount of latent removal and latent addition from Figure 22 shows that the unit provides about 5.4 MBtu of latent cooling while the compressor is on and loses about 4.0 MBtu of latent cooling while the compressor is off, providing only 1.4 MBtu of latent net cooling per cycle. When the compressor is off, the process is roughly adiabatic, meaning no actual energy overall is removed from the air. The unit provides sensible cooling to the space while the compressor is off but much of the sensible cooling results in an equal loss of latent cooling. Not only does on/off compressor cycling waste energy and provide very little latent cooling but it also creates large variations in the room humidity which can make the space uncomfortable for its occupants.

AAON single zone VAV systems reduce the latent cooling losses due to the cycling of the on/off compressor by lowering the fan speed and utilizing a variable capacity compressor, which can modulate its capacity from 10% to 100%, to satisfy the cooling load instead of simply turning the compressor on and off.

## Why Single Zone VAV?

Single zone VAV systems modulate the supply fan speed based on the space temperature and modulate the variable capacity compressor based on the supply air temperature to provide variable airflow at a constant supply air temperature to control the space temperature of a single zone. With both variable speed fans and variable capacity compressors, which have a wide range of modulation capabilities and can adapt to full and part load conditions, AAON is leading the industry in single zone VAV technology.

There are many benefits to a single zone VAV system. With the modulation capabilities of both the fan and compressor, a single zone VAV system can provide precise temperature control and additional passive dehumidification. Because of the modulating capability of the variable capacity compressor, and therefore a reduction in on/off cycling, single zone VAV systems reduce the wear on the compressor and save energy with less cycling losses caused by inrush current. Lower fan speeds during part load operation reduce the amount of system sound and significantly reduce the system energy consumption. Finally, because the entire modulating control for part load operation is provided within the HVAC unit, a single zone VAV system is simple to install, set up and maintain.

Single zone VAV units are a better alternative to all constant volume units due to the ability to adapt to normal swings in room conditions. With a single zone VAV system, a building owner will have a more comfortable environment, reduce HVAC system energy consumption, lower sound levels and save money. The versatility of single zone VAV makes single zone VAV a superior choice that provides better results for all HVAC applications.

**Contact your local AAON representative to see how  
an AAON single zone VAV unit would benefit you.**



**Defining Quality. Building Comfort.**

2425 S. Yukon Ave. • Tulsa, OK 74107-2728 • [www.AAON.com](http://www.AAON.com)

It is the intent of AAON to provide accurate and current product information. However, in the interest of product improvement, AAON reserves the right to change pricing, specifications, and/or design of its product without notice, obligation, or liability. Copyright © AAON, all rights reserved throughout the world. AAON® and AAONAIRESM are registered trademarks of AAON, Inc., Tulsa, OK.